

FRESCOR: contract-based resource management in distributed systems

Daniel Sangorrín López
daniel.sangorin@unican.es

Michael González Harbour
mgh@unican.es

Service Contracts

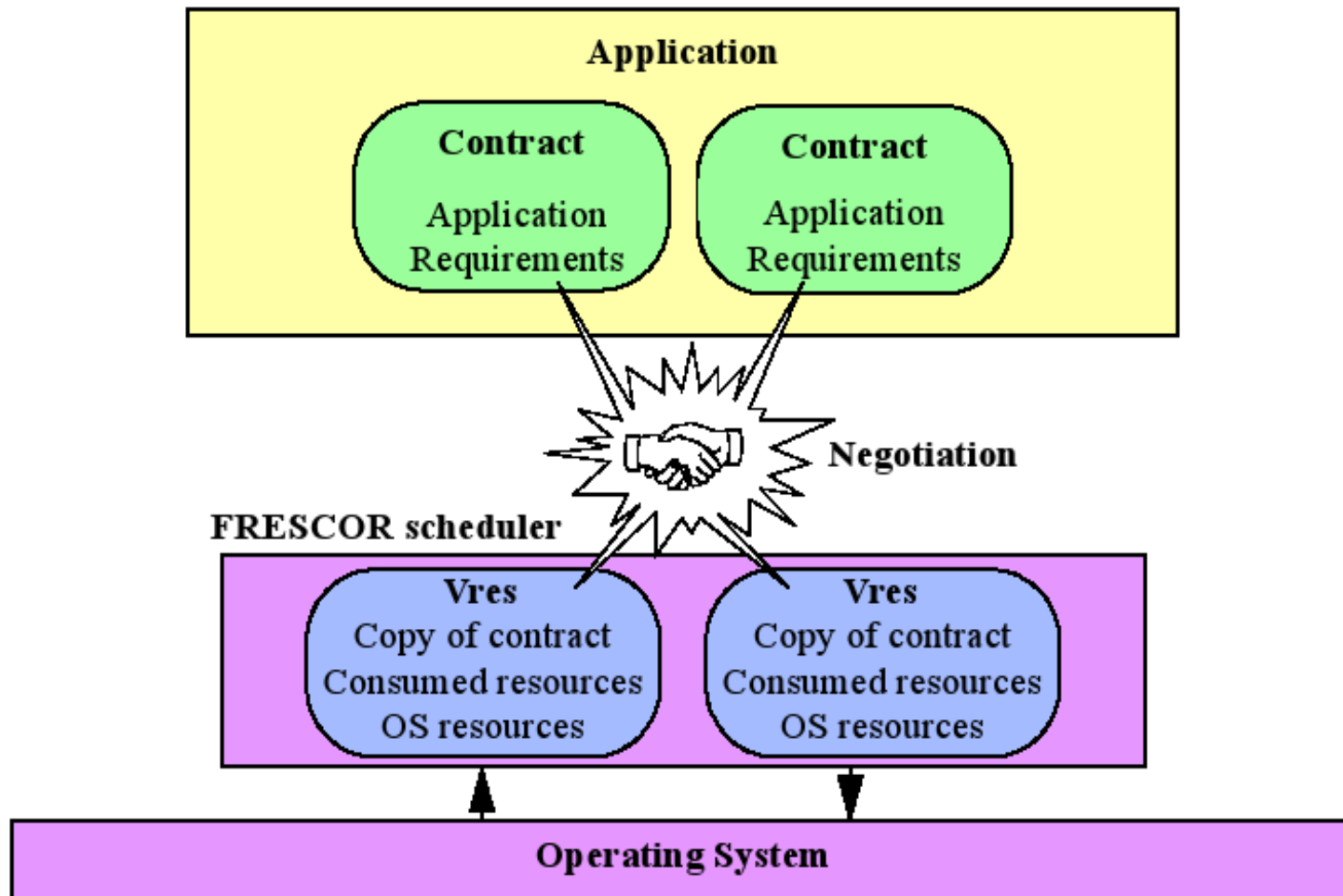

FRESCOR Modules

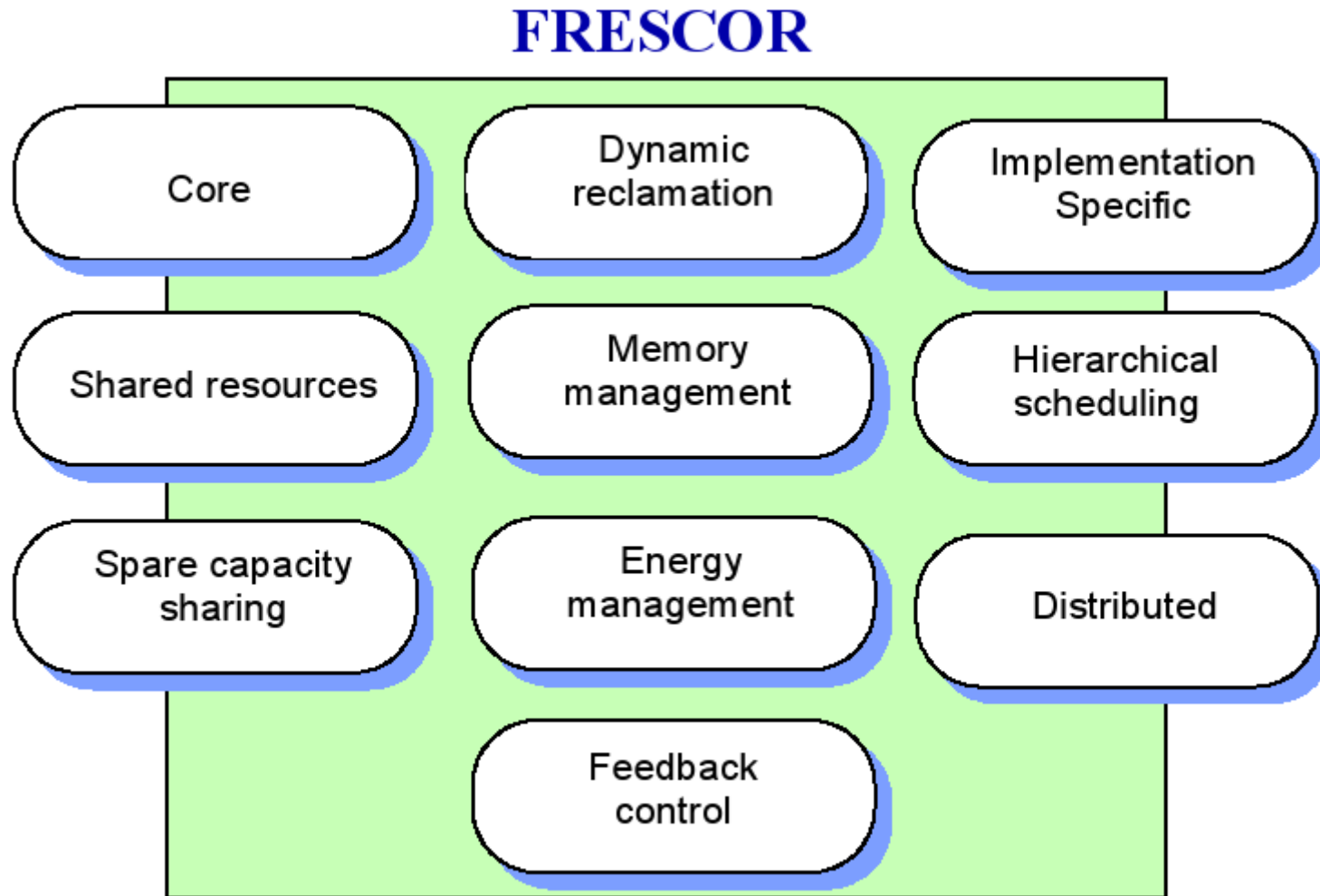

Core Services

Name	Description
label	Global ID
resource type	Processor, network, memory, ...
resource id	An identifier of the resource
min budget	Min execution capacity per vres period
max period	Maximum virtual resource period
deadline	The deadline of the virtual resource

Spare Capacity Services

<i>Name</i>	<i>Description</i>
max budget	maximum usable budget
min period	minimum useful period
granularity	discrete or continuous
discrete gran set	pairs {budget,period} discrete gran
importance	priority to distribute extra cap.
weight	for vres with the same importance
stability time	minimum time vres must not change

Distributed services

Send Endpoints

- Bound to a network vres
- Keep track of consumed bandwidth
- Store destination info

Receive Endpoints

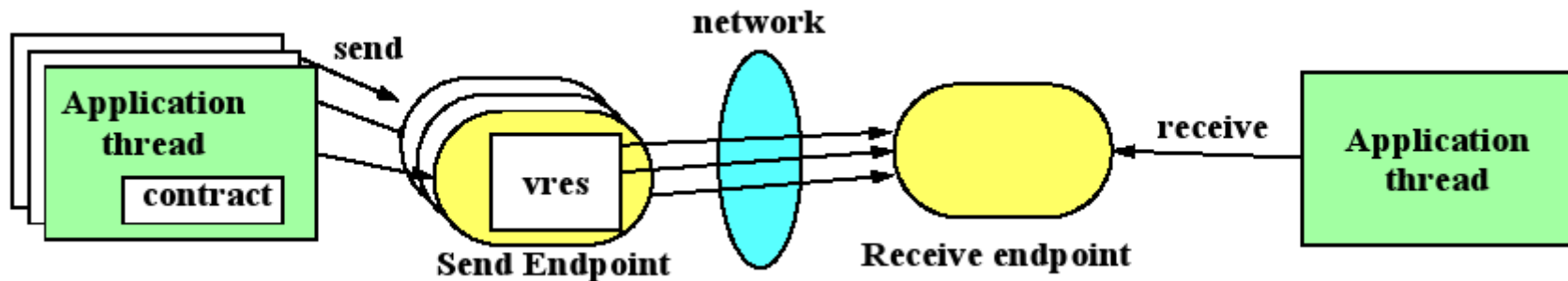

Distributed transaction

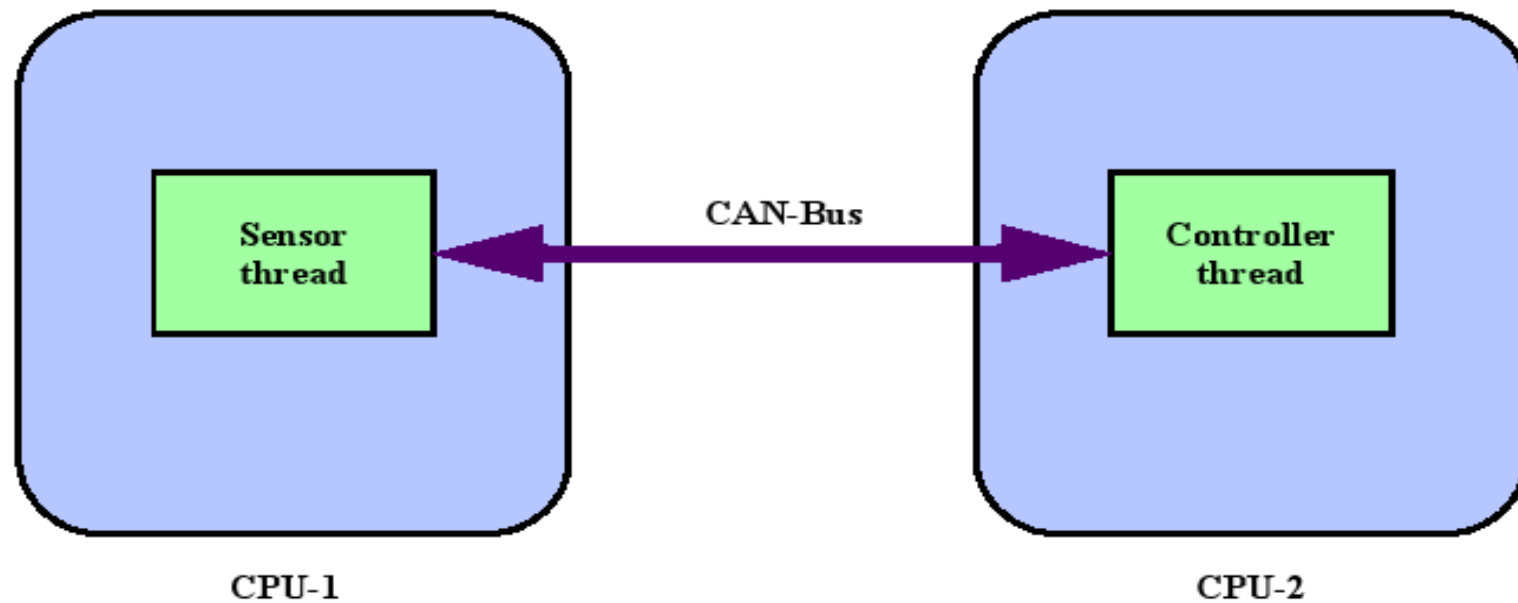

Distributed transaction

Sensor thread

```
create CPU contract
negotiate the CPU contract
create Network contract
negotiate the Network contract
create send_endpoint
bind vres to send_endpoint

while (1) {
    read sensor
    send message
    frsh_schedule_timed_job
}
```

Controller thread

```
create contract
negotiate the contract
create receive endpoint

while (1) {
    read message
    process message
}
```

Network Protocols Plug-Ins

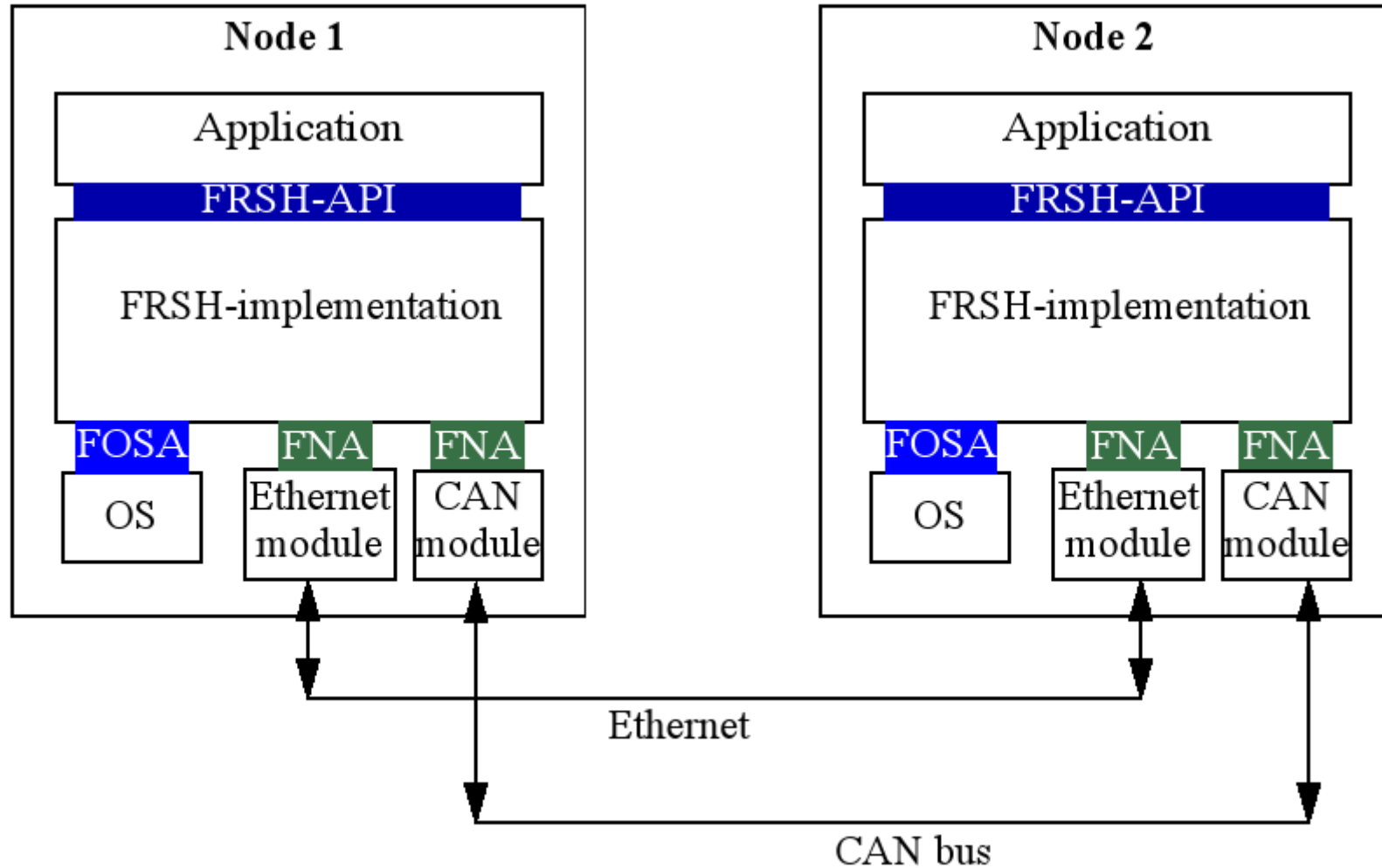

FRESCOR: contract-based resource management in distributed systems

Daniel Sangorrín López
daniel.sangorin@unican.es

Michael González Harbour
mgh@unican.es

QUESTIONS?